



WR10 Waveguide 1W Variable Attenuator 73.8 - 112GHz



Note: The photo is for illustration purposes only.
Please refer to outline drawing



Features

- WR10 Waveguide Variable Attenuator
- High Power Handling Capability
- Low Insertion Loss
- Customization available upon request

Electrical Specifications , $T_A=25^\circ C$

Parameter	Min.	Typ.	Max.	Units
Frequency Range	73.8		112	GHz
VSWR			1.35	: 1
Power Rating(CW)			1	W
Insertion Loss			2	dB
Attenuation Range (Relative to IL)		35		dB
Waveguide Type	WR10			
Flange type	UG387			
Flange Holes	Through			
Material	Copper/Brass			
Finish	Gold Plated			

Environmental Specifications and Test Standards

Parameter	Standard	Description
Operational Temperature	MIL-STD-39016	-40°C~+85°C
Storage Temperature		-55°C~+125°C
Thermal Shock		1 Hour@ -45°C → 1 Hour @ +85°C (5 Cycles)
Random Vibration		Acceleration Spectral Density 6 (m/s) Total 92.6 RMS
Electrical & Temperature Burn In		Temperature +85°C for 72 Hours
Shock		1. Weight >20g, 50g half sine wave for 11ms, Speed variation 3.44m/s 2. Weight <=20g, 100g Half sine wave for 6ms, Speed variation 3.75m/s 3. Total 18 times (6 directions, 3 repetitions per direction).
Altitude		Standard: 30,000 Ft (Epoxy Sealed Controlled Environment) Optional: Hermetically Sealed (60,000 ft. 1.0 PSI min)
Hermetically Sealed (Optional)	MIL-STD-883	MIL-STD-883 (For Hermetically Sealed Units)

WR10 Waveguide 1W Variable Attenuator 73.8 - 112GHz



Typical Performance Plots

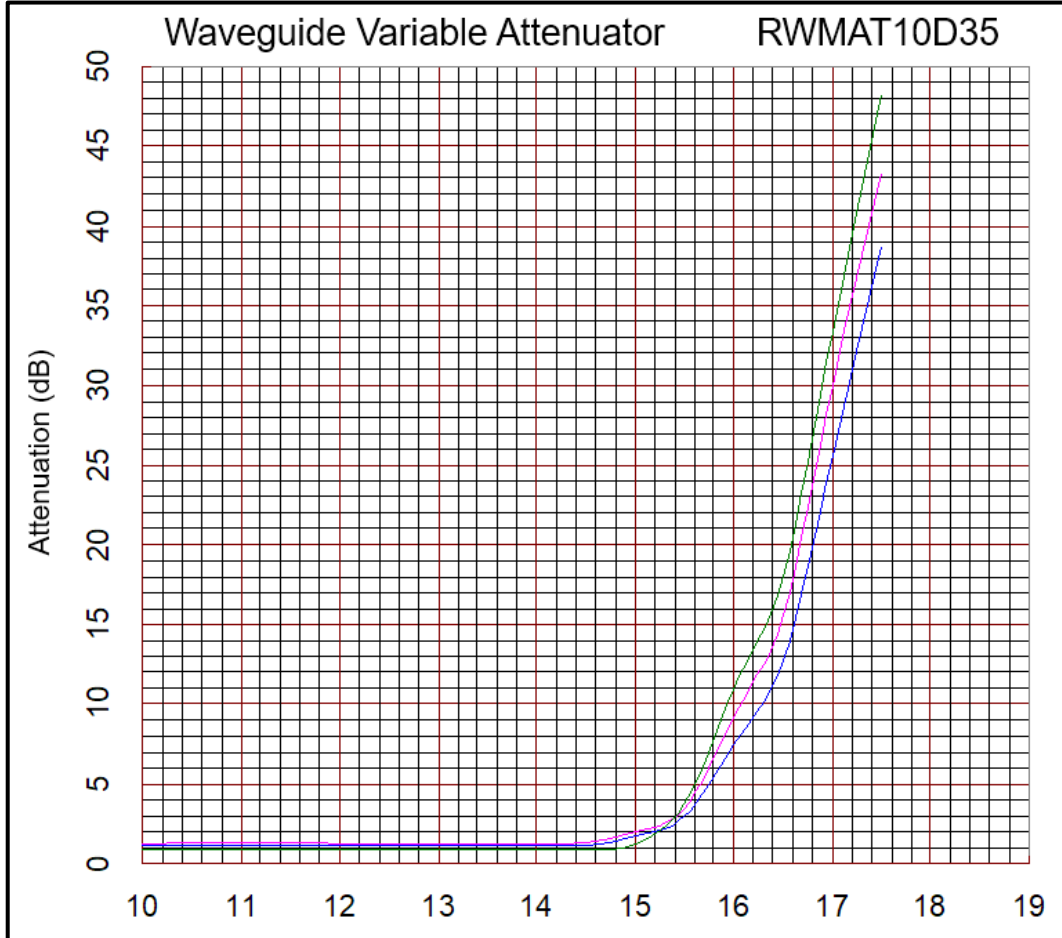

— F1=73.8GHz — F2=91.9GHz — F3=110GHz

Scale (mm)	10.0	10.5	11.0	11.5	12.0	12.5	13.0	13.5	14.0	14.5
F1= 73.8GHz	1.1089	1.1125	1.1240	1.1371	1.1328	1.1464	1.1508	1.1389	1.1418	1.1630
F2= 91.9GHz	1.2836	1.2963	1.2965	1.2931	1.2757	1.2828	1.2674	1.2675	1.2707	1.2928
F3= 110GHz	0.8468	0.8454	0.8580	0.8623	0.8583	0.8723	0.8594	0.8679	0.8696	0.9013

Scale (mm)	15.0	15.5	16.0	16.5	17.0	17.5				
F1= 73.8GHz	1.7537	2.9166	7.4415	12.7072	25.5006	38.737				
F2= 91.9GHz	1.9744	3.4402	9.1666	15.5671	30.0103	43.2694				
F3= 110GHz	1.2742	3.6935	10.8682	18.0894	33.3764	48.2853				

WR10 Waveguide 1W Variable Attenuator 73.8 - 112GHz



Outline Drawing:

All Dimensions in mm [inches]

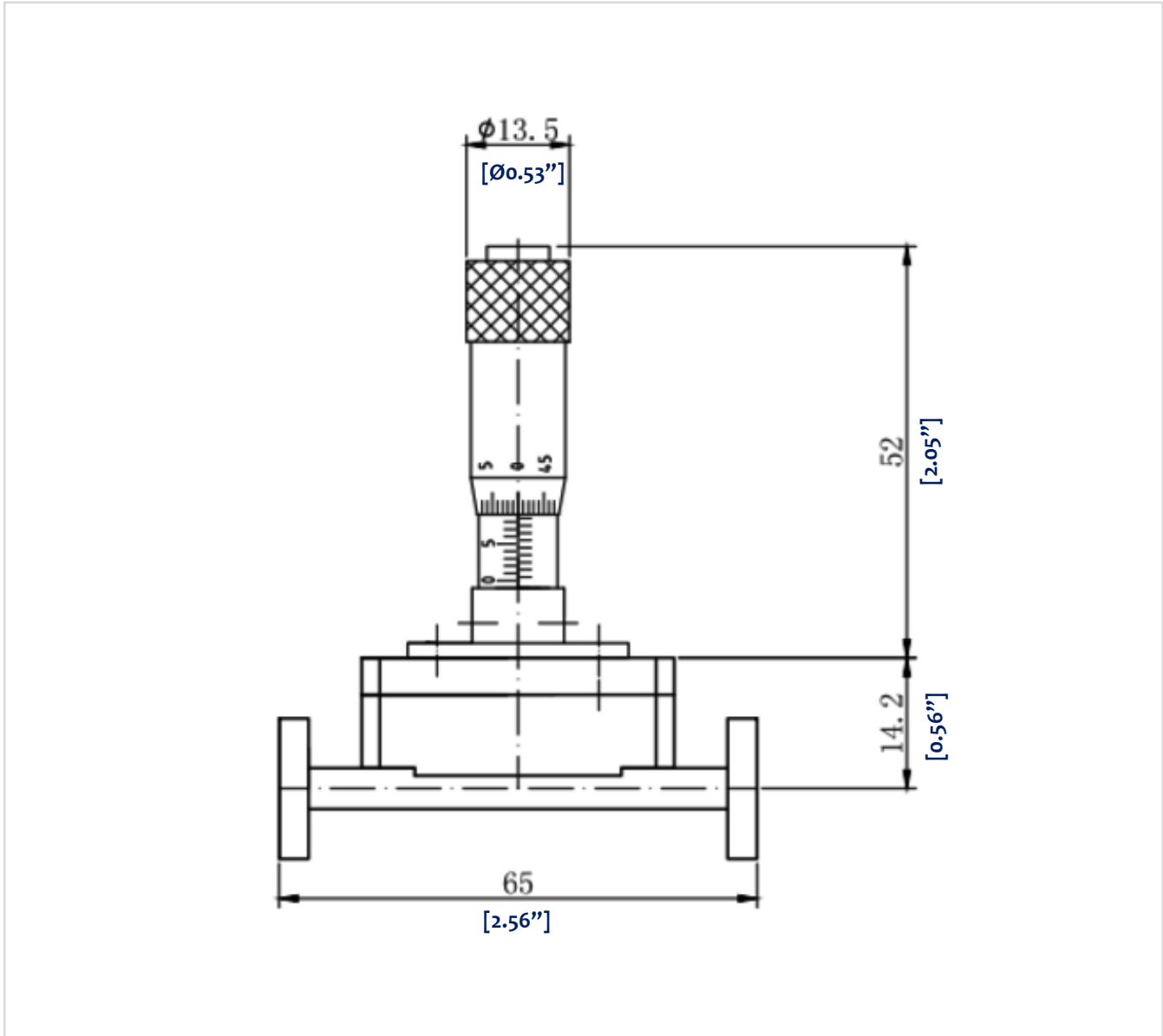

WR10 Waveguide 1W Variable Attenuator 73.8 - 112GHz

Important Notice

The information contained herein is believed to be reliable. RF-Lambda makes no warranties regarding the information contained herein. RF-Lambda assumes no responsibility or liability whatsoever for the use of the information contained herein. RF-Lambda assumes no responsibility or liability whatsoever for the use of the information contained herein. The information contained herein is provided "AS IS, WHERE IS" and with all faults, and the entire risk associated with such information is entirely with the user. All information contained herein is subject to change without notice. Customers should obtain and verify the latest relevant information before placing orders for RF-Lambda products. The information contained herein or any use of such information does not grant, explicitly or implicitly, to any party any patent rights, licenses, or any other intellectual property rights, whether with regard to such information itself or anything described by such information. RF-Lambda products are not warranted or authorized for use as critical components in medical, life-saving, or life sustaining applications, or other applications where a failure would reasonably be expected to cause severe personal injury or death.